

Technical presentation of the

**CLAMPING ANGLE PLATES UU 800, UU 950, UU 1120, UU 1450
UU 1620, UU 2000, UU 2500, UU 3000, UU 3500, UU 4000,
UU 4500, UU 5000, UU 6000**

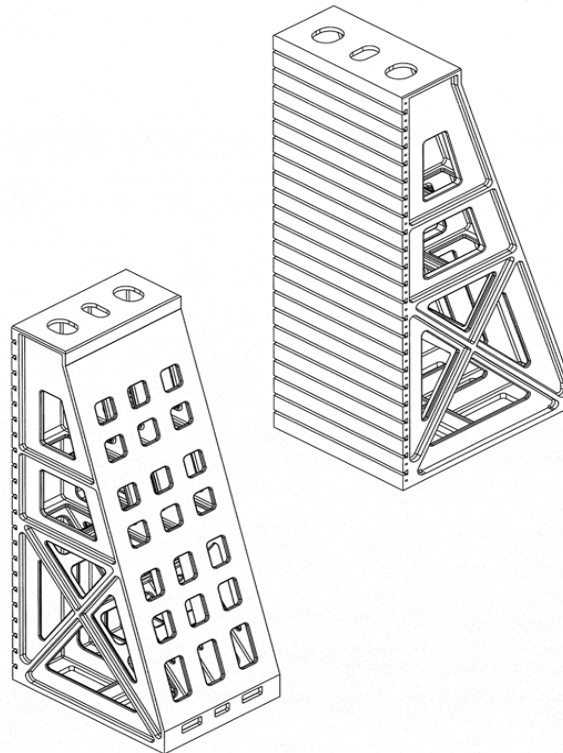

1. PRODUCT FEATURES

The clamping angle plates with size 800 to 6000 are designed as optional accessories for horizontal boring machines. They serve for clamping of workpieces and they are anchored to the clamping table or just to floor plates.

2. DESCRIPTION AND SPECIFICATIONS

The angle plates UU 800 – UU 4500 are cast of high-quality cast iron and their grid ribbing lends them an excellent rigidity.

The angle plates UU 5000 and UU 6000 are designed as a thin-walled steel weldment.

We offer two types of angle plates according to size:

3. TYPE 1 (angle plates height 800, 950, 1120, 1450)

Denomination	Dimensions (mm)							T- slots			Weight (kg)
	X	Y	Z	S	h	l	t	width	pitch	numb.	
UU 800	320	800	500	320	70	120	125	22 H12	160	5	350
UU 950	500	950	500	560	80	145	140	22 H12	160	6	600
UU 1120	320	1120	600	320	80	150	140	22 H12	160	7	500
UU 1450	500	1450	650	560	80	148	160	22 H12	160	9	1000

OVERALL SETUP (angle plates height 800, 950, 1120, 1450)

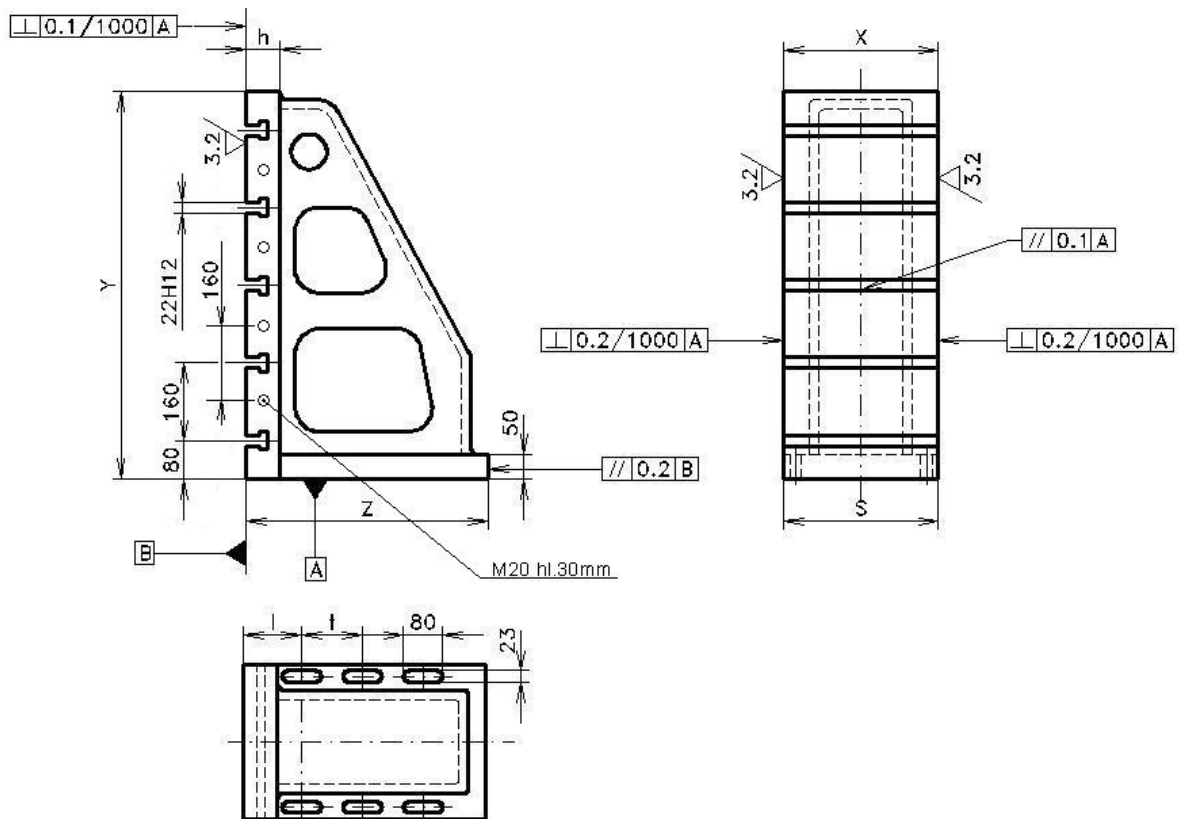

4. TYPE 2 (angle plates height 1620, 2000, 2500, 3000, 3500, 4000, 4500, 5000, 6000)

Denomination	Dimensions (mm)			h	T- slots			Weight (kg)
	X	Y	Z		width	pitch	numb.	
UU 1620	700	1620	725	80	22 H12	175	9	1470
UU 2000	800	2000	1000	80	22 H12	175	11	2500
UU 2500	1000	2500	1200	80	22 H12	175	14	4000
UU 3000	1200	3025	1500	80	28 H12	175	17	4500
UU 3500	1300	3500	1600	80	28 H12	175	19	7000
UU 4000	1300	4000	1700	80	28 H12	175	22	7870
UU 4500	1300	4500	1700	80	28 H12	175	25	8550
UU 5000	1300	5000	1880	70	28 H12	200	24	8970
UU 6000	1500	6000	2080	70	28 H12	200	29	12000

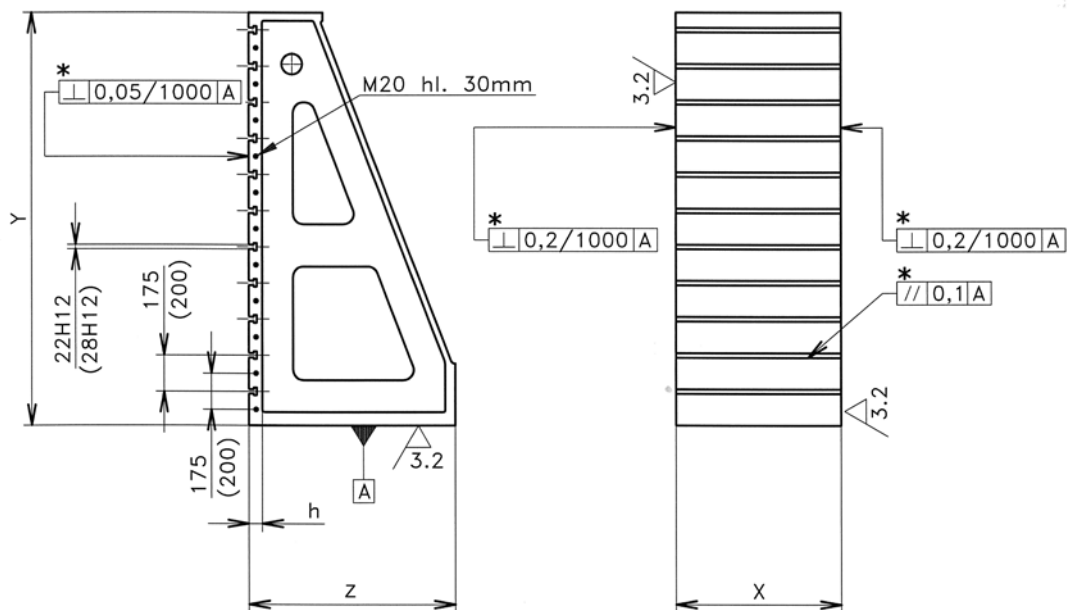
OVERALL SETUP (angle plates height 1620, 2000, 2500, 3000, 3500, 4000, 4500, 5000, 6000)

* Tolerance accuracy according to technical documentation of TOS VARNSDORF.

5. LIST OF STANDARD ACCESSORIES

- Accompanying Technical documentation